

— TECHNICAL ARTICLE

POWER ARCHITECTURES FOR PATIENT CONNECTED MEDICAL DEVICES

This paper discusses approaches for power architectures within medical devices for patient connected applications. There are several key elements to consider; isolation, leakage/touch currents, Electro-Magnetic Compatibility (EMC), number of power outputs required and environment for use.

By Gary Bocock, Technical Director, XP Power

Applied Parts

The element of the medical device which comes into contact with the patient is known as the applied part.

The applied part is defined as the part of the medical device which, in order for the medical device to perform its function, deliberately comes into direct contact with a patient or has parts which are likely to come into contact with the patient during normal use.

The 60601-1 suite of standards defines Applied Parts according to the type of patient contact and the type or nature of the medical device. The current version of 60601-1 is the 3rd edition which was first published in December 2005 has been adopted in all major countries and regions of the world as the following latest versions:

IEC 60601 1:2005 (Third Edition) + CORR. 1:2006 + CORR. 2:2007 + A1:2012

Europe: EN 60601-1:2006/A1:2013/A12:2014

USA: ANSI/AAMI ES60601-1: A1:2012, C1:2009/(R)2012 and A2:2010/(R)2012

Canada: CSA CAN/CSA-C22.2 No. 60601-1:14

Each classification within the standard has requirements for protection against electric shock. The three classifications are detailed below, in order of the least stringent to the most stringent: Type B (Body). Type B classification is given to applied parts which are generally not conductive and may be connected to Earth. Type BF (Body Floating).

Type BF classification is given to applied parts which are electrically connected to the patient and must be floating and separated from Earth. This classification does not include applied parts which are in direct contact to the heart.

Type CF (Cardiac Floating). Type CF classification is given to applied parts suitable for direct cardiac connection. This means connection to the heart of the patient including intravenous connection such as dialysis. T

These applied parts must be floating and separated from Earth.

Isolation Requirements

Patient connected medical devices are required to provide two Means Of Protection (MOP) to prevent applied parts and other accessible parts from exceeding the limitations of voltage, current or energy.

A compliant protective earth connection provides 1 MOP, basic isolation also provides 1 MOP & Reinforced insulation provides 2 MOP. Means of protection can be categorised as Means Of Operator Protection (MOOP) or Means Of Patient Protection (MOPP). In devices intended for patient connection 2 x MOPP are required.

Power architectures for use in medical devices with type BF & CF classification are required to provide 2 x MOPP from primary to secondary, 1 x MOPP from primary to earth and additional safety isolation from the secondary output of the power system to earth also rated at 1 x MOPP, all at the (highest rated) incoming AC line voltage.

Power architectures for use in medical devices with type BF & CF classification are required to provide 2 x MOPP from primary to secondary, 1 x MOPP from primary to earth and additional safety isolation from the secondary output of the power system to earth also rated at 1 x MOPP, all at the (highest rated) incoming AC line voltage.

Insulation	MOOP			MOPP		
	Air Clearance	Creepage Distance	Test Voltage	Air Clearance	Creepage Distance	Test Voltage
Basic (1 x MOP)	2.0 mm	3.2 mm	1500 VAC	2.5 mm	4.0 mm	1500 VAC
Double of Reinforced (2 x MOP)	4.0 mm	6.4 mm	3000 VAC	5.0 mm	8.0 mm	4000 VAC

Insulation test voltages based on 250 VAC working voltage.

Key:

MOP: Means of Protection

MOOP: Means of Operation Protection

MOPP: Means of Patient Protection

Leakage Currents

Additionally, the power system must be designed to limit the touch current, patient auxiliary current and patient leakage current. The maximum allowable values for the touch current are 100µA in normal conditions and 500µA in a Single Fault Condition (SFC), which effectively limits the system earth leakage current to 500µA in normal operation. The maximum allowable patient auxiliary current and patient leakage currents are defined in the table below.

Insulation	Description		Type B Applied Part		Type BF Applied Part		Type CF Applied Part	
			NC	SFC	NC	SFC	NC	SFC
Patient Auxiliary Current		d.c.	10	50	10	50	10	50
		a.c.	100	500	100	500	10	500
Patient Leakage Current	From PATIENT connection to earth	d.c.	10	50	10	50	10	50
		a.c.	100	500	100	500	10	500
	Caused by an external voltage on a SIP/SOP	d.c.	10	50	10	50	10	50
		a.c.	100	500	100	500	10	500
Total Patient Leakage Current*	With the same types of APPLIED PART connected together	d.c.	50	100	50	100	50	100
		a.c.	500	1000	500	1000	50	1000
	Caused by an external voltage on a SIP/SOP	d.c.	50	100	50	100	50	100
		a.c.	500	1000	500	1000	50	1000

Current in µA

Key:

NC: Normal Condition

SFC: Single Fault Condition

* Total PATIENT LEAKAGE CURRENT values are only applicable to equipment having multiple APPLIED PARTS. The individual APPLIED PARTS shall comply with the PATIENT LEAKAGE CURRENT values.

The challenge for the power system architecture designer in patient contact medical devices, where an electrical connection is required, is to ensure that the power system provides the required safety isolation while minimising the leakage currents under normal operation and protecting under fault conditions, by isolating the patient from ground.

Electro-Magnetic Compatibility (EMC)

The medical device must also comply with the EMC requirements outlined in the 60601-1-2. An updated version of the medical EMC standard IEC60601-1-2 was published in 2014, widely referred to as the 4th Edition. There are two main aims of the 4th Edition revisions.

The first is to improve immunity of equipment partly due to the proliferation of wireless communication devices operating within the local proximity of what may essentially be life critical equipment. These wireless devices may take the form of mobile phones, blue-tooth, WiFi, Tetra, RFID or paging system products.

The second aim is to introduce an element of risk analysis into deciding which levels of immunity are suitable for the equipment, its intended operating environment and foreseeable levels of disturbances. This is due to the inclusion into the standard of equipment intended to operate outside of hospital or professional healthcare environments in which there is less supervision of equipment and less control over the electro-magnetic phenomena present. Part of the risk approach is that manufacturers must be clear about the essential operation of their product and mitigate the risk of failure or abnormal or unexpected operation by choosing the appropriate immunity levels.

The 4th Edition considers three environments: professional health care facility, home health care and special environments, examples of which could include heavy industry or medical equipment intentionally generating high power fields. As the required immunity levels now relate to these environments rather than to the product, the term 'life supporting equipment' is no longer used.

Power Solutions

In BF & CF rated medical devices, the power system is a critical factor in complying with isolation, leakage current and EMC requirements.

For home healthcare environments, it is mandated to select an isolation scheme where there is no earth required, by implementing a class II isolation system which is naturally floating, but importantly, must still comply with requirements for enclosure and patient leakage currents to earth. This is a practical solution up to around 300Watts, above which the EMC requirements become increasingly difficult to manage.

The majority of standard medically approved AC—DC power supplies are not suitable for direct connection to the patient for a number of reasons: -

1. They do not have the required isolation from output to ground.
2. They do not meet the requirements for patient leakage current.
3. While they may offer the required 2 x MOPP from input to output and 1 x MOPP from input to ground, most of these units employ operational isolation from output to ground, often rated around 500VAC/VDC, when patient connect applications require a minimum of basic insulation at mains voltage, where the test voltage required is 1500VAC and the creepage and clearance distances must be adhered to.
4. The isolation capacitance from input to output is too high, resulting in excessive leakage current from output to ground.

A simple and low-cost solution, for low power patient connected medical devices, is to employ a second isolation stage in the form of a medically approved DC-DC converter which provides both basic isolation at AC line voltage and minimises input to output capacitance (20 – 50pF) reducing the potential patient leakage current to single digit μA . This solution also accounts for potentially low integrity system input and output signals which may be connected to uncontrolled external equipment such as a computer or monitor.

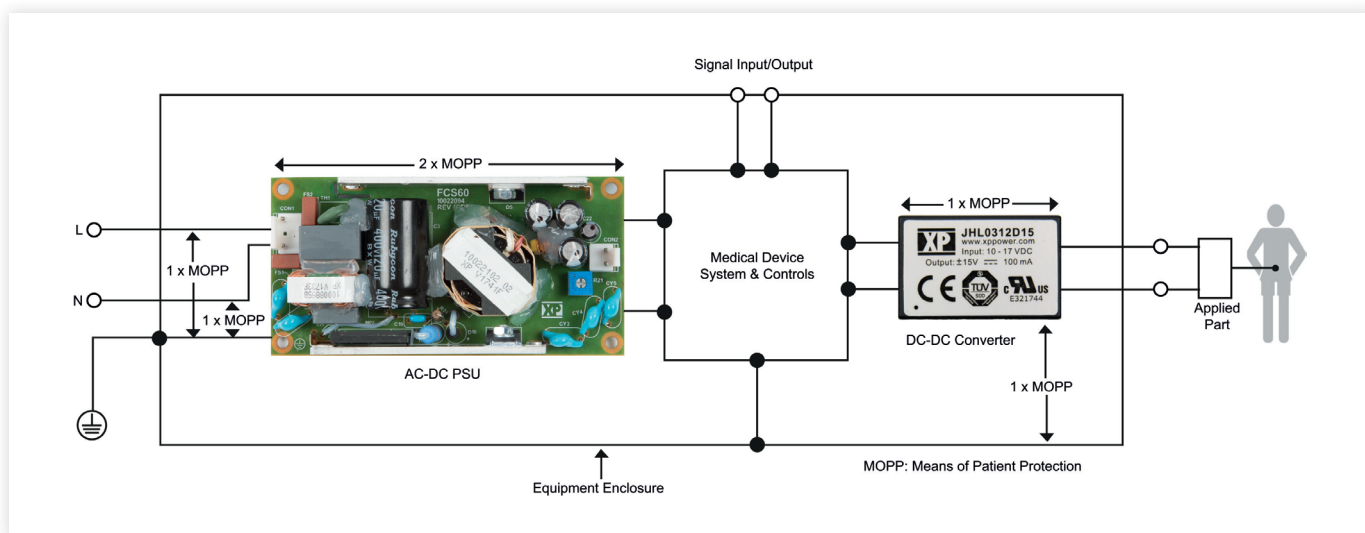

Figure 1: Medical power system with secondary DC-DC.

In the simplified model of the power system below the path for patient leakage current is shown with C4 & C5 in series. C5 represents the DC-DC converter input to output capacitance which is very small and presents a high impedance to reduce the leakage current regardless of the typically higher value of C4.

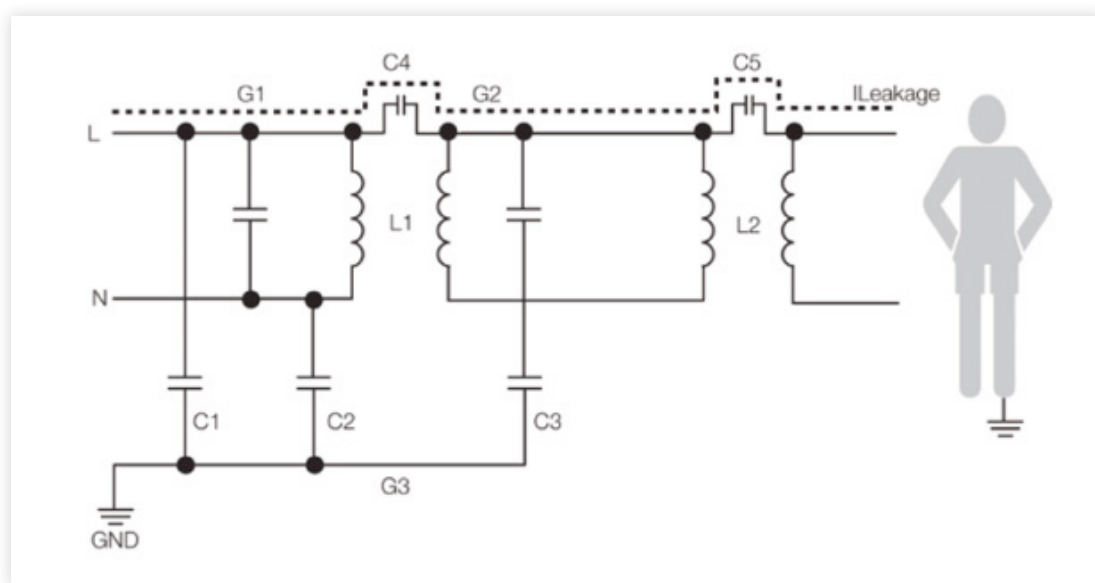

Figure 2: Simplified model for power system with secondary DC-DC isolation.

Medically approved DC-DC converters with output ratings from 1W up to 20W are readily available, with the required input to output isolation and very low internal capacitance, designed specifically for these applications at a competitive cost and carrying agency approvals to the 60601 standards. When used in conjunction with a standard medically approved mains input power supply, patient leakage current can be reduced to levels as low as 2µA suitable for use in both BF & CF applications. Where the supply to the DC/DC converter is from a regulated AC-DC power supply and the power required is less than 2-3 Watts, a fixed input, non-regulated output device can be used resulting in a very cost-effective solution.

Wide range input DC/DC products, offering a tightly controlled output over a wide DC input and output load range, with up to 2 x MOPP isolation and equally low internal capacitance are also readily available for DC input or battery powered portable devices.



Figure 3: XP Power’s medically approved DC-DC converters from 1 Watt to 20 Watts.

Power solutions for multiple outputs

In medical devices requiring multiple outputs for patient contact, the low leakage current provided by the additional DC-DC converter which may be as low as 2µA provides an easy to implement robust solution to both patient auxiliary and patient leakage current requirements.

Where multiple outputs are required in the AC-DC stage the complication becomes the earth leakage current which is limited by the SFC touch current and makes the use of multiple power supplies impractical. In this instance a multiple output AC-DC supply may be required.

For lower power systems, up to 2-300W, there are multiple output medically approved units available in open frame or U-channel formats or, alternatively, extra voltage rails may be created using isolated or non-isolated off the shelf

DC/DC converters running from a single output AC-DC power supply.

For higher power applications there are readily available configurable solutions providing high power multiple output power solutions with medical safety agency approvals as standard, such as the fleXPower series pictured below.



Figure 4: Medically approved fleXPower series offers from 400 Watts to 2500 Watts with up to 20 outputs

Motor driven applications

In higher power devices and motor driven applications, such as bone shavers, surgical tools and electrically powered tables, beds & chairs, it is not desirable to employ an additional isolation stage due to both the poor availability of suitably isolated DC/DC devices with higher power ratings and the inherent inefficiency of dual conversion of the power. In these applications a power supply designed with the necessary isolation, spacing and patient leakage current is required.

This combination of high isolation and low leakage currents presents its own design challenges in an AC-DC supply. The internal spacing requirement on the secondary side is greatly increased and must be implemented with system integration in mind. The requirements for low emissions and low leakage current are in conflict, requiring a low noise topology and care in minimising differential and common mode noise throughout the product while minimising the line frequency ripple in primary circuits to reduce patient leakage current for the same input to output capacitance.

These higher power applications are usually BF rated, rather than CF rated, meaning that the patient leakage current requirement, while challenging, is less severe at 100µA rather than 10µA and there are increasing numbers of standard AC-DC power supplies available which suit BF rated applications. XP Power's new 250W, BF rated, CMP250 series for example, comes with the isolation, leakage current and 4th edition EMC requirements catered for with the added benefit of convection cooling to eliminate noisy system fans and combines a constant current overload characteristic with up to two times peak power for up to one minute making it ideally suited to motor driven applications.



Figure 4: Medically approved fleXPower series offers from 400 Watts to 2500 Watts with up to 20 outputs